

ULTRA-WIDEBAND PULSE WAVEFORM GENERATION BASED ON COMBINING SUBNANOSECOND GAUSSIAN PULSES

Pavel Protiva,¹ Jan Mrkvice,² and Jan Macháč¹

¹Department of Electromagnetic Field, Faculty of Electrical Engineering, Czech Technical University in Prague, Technická 2, 166 27 Praha 6, Czech Republic; Corresponding author: protip1@fel.cvut.cz

²RETIA, a.s., Pražská 341, Zelené Předměstí, 530 02 Pardubice, Czech Republic

Received 29 January 2010

ABSTRACT: A technique for generating ultra-wideband pulse waveforms is described in this article. It consists in combining subnanosecond Gaussian pulses from multiple sources. This method enables us to form complex pulse waveforms without the need to use transmission line pulse forming networks and delay lines. Two designs for an experimental generator utilizing the pulse combining principle are presented. The first generator is composed of two positive Gaussian pulsers and one negative Gaussian pulser. Analog time shifters were used to control the timing of each pulser. The circuit can be used as the generator of a Gaussian doublet. The second generator is composed of four identical Gaussian pulsers. Programmable ECL logic delay chips were employed to adjust the timing in this case. The measurements demonstrate the wide capability of the pulse combining scheme for controlling the spectral properties of the pulse waveform that is generated. © 2010 Wiley Periodicals, Inc. *Microwave Opt Technol Lett* 52:2401–2405, 2010; View this article online at wileyonlinelibrary.com. DOI 10.1002/mop.25498

Key words: ultra-wideband systems; subnanosecond pulse; pulse generator; pulse shaping; pulse combining; time shifter

1. INTRODUCTION

An ultra-wideband (UWB) subnanosecond pulse generator is a fundamental part of any transmitting or receiving UWB system. The spectral properties of a transmitted signal are determined by the modulation technique, the multiple access scheme, encoding, and most critically by the frequency spectrum of the underlying UWB pulse. Therefore, synthesis of the UWB pulse is a crucial step when designing UWB waveforms for a specific spectral mask, to match the transmitting antenna bandwidth or to avoid narrowband interference with coexisting wireless devices and networks.

A great variety of techniques may be used to generate UWB waveforms. Nowadays, a precise UWB signal waveform design using either digital logic CMOS circuits [1] or DSP-based FIR

filters [2] is preferred. Digital pulse design is mostly utilized for the multiband UWB scheme, which is primarily suitable for low power high data rate UWB communication over a short range. On the other hand, impulse UWB is appropriate for UWB sensor networks, imaging and localization systems. In this field, the traditional method for generating UWB pulses is still widely used [3]. This approach involves generating a very sharp voltage step or a short Gaussian pulse in time [4–6]. Pulse forming networks, which are essentially microwave filters, are then applied to reshape the pulse to provide desirable spectral properties. A simple pulse forming network consisting of a shorted stub connected in parallel with a transmission line is described in [7]. This structure operates similarly to a first-order differentiator, and it is therefore frequently used to form Gaussian or monocycle pulses [8]. Higher-order differentiators are implemented as multisectional structures [9]. However, transmission line pulse forming networks offer low flexibility to control pulse shaping, although some experiments with electronically tunable [10] or reconfigurable [11] pulse generators have been presented in the literature. Other disadvantages are insertion loss and high output ringing, which arise as a consequence of multiple reflections in the structure of the network. In most cases, additional circuits have to be employed to suppress ringing [12], and this introduces additional power loss.

An alternative method for pulse waveform design is to combine UWB pulses. In our previous article [13], we combined two identical Gaussian pulses to increase the output power of a transmitter. In [14], a UWB pulse synthesizer based on distributed amplifier topology is presented. An output pulse with 4 GHz center frequency and 1 ns pulse envelope width is formed by combining different delayed copies of an input Gaussian pulse. Combining UWB pulses is a difficult task. Up to now several power dividers/combiners have been described in the literature. Traditional power combining structures, e.g., the Wilkinson power divider and modifications of it [15], are fundamentally narrowband, and they distort UWB waveforms. Combiners showing appropriate UWB performance have also been presented, see [16–18]. Unfortunately, these designs are suitable primarily for the higher UWB band (3.1–10.6 GHz). There is no known implementation of a microwave power combiner capable of combining baseband Gaussian or monocycle pulses, which have the maximum of spectral energy concentrated at low frequencies.

In this article we present two UWB pulse generator circuits based on a pulse combining scheme. The purpose of the first generator is similar to the circuit described in [14]—we combine

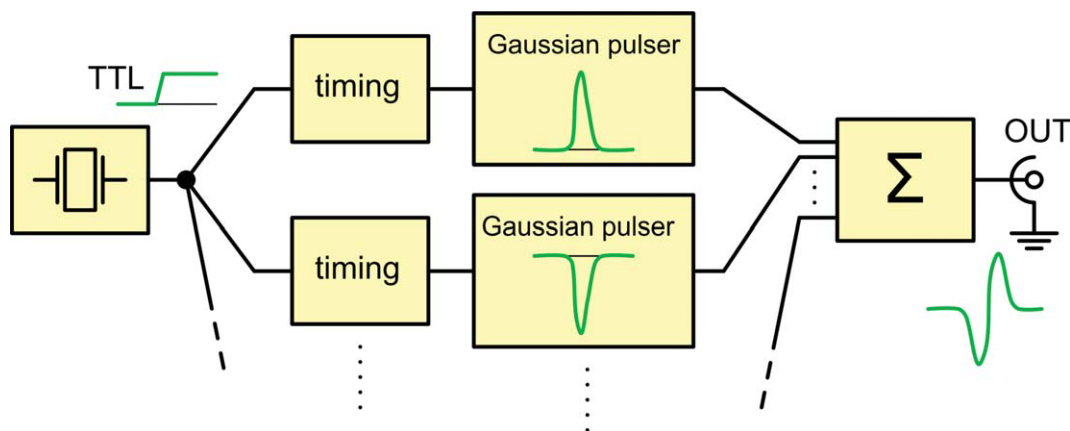

Figure 1 General structure of the pulse combining technique. [Color figure can be viewed in the online issue, which is available at wileyonlinelibrary.com]

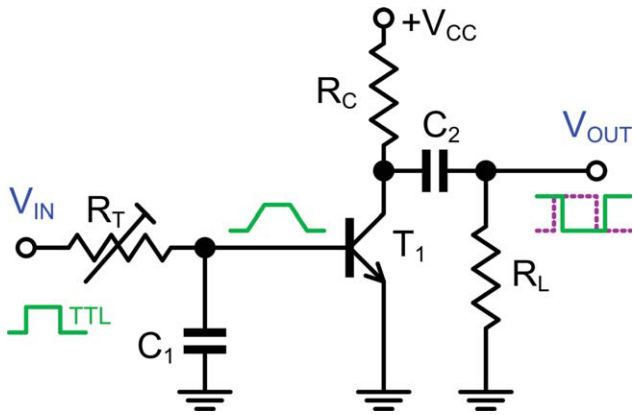

Figure 2 Analog time shifter. [Color figure can be viewed in the online issue, which is available at wileyonlinelibrary.com]

baseband Gaussian pulses with different delays and amplitudes to form an output UWB pulse with a desired shape and frequency response. Compared to [14], we use an array of independent Gaussian pulsers, the outputs of which are collected by a passive pulse combiner providing their sum at the output. The delays are introduced to the triggering signals of each pulser. In the second designed generator, the delays are controlled by digital delay chips, which provide the possibility to create simple UWB modulation schemes. Although we use low power transistor Gaussian pulsers to demonstrate the capability of the pulse combining technique, it can easily be redesigned with any other UWB source.

2. PULSE COMBINING TECHNIQUE

A block diagram of a generator based on the pulse combining scheme is shown in Figure 1. A common triggering signal is supplied to an array of Gaussian pulsers. The timings of each pulser, and thus the time position of the generated Gaussian pulses, are controlled individually by the time shifters. Finally, the output signals of the array are summed in a pulse combiner. A detailed description of these subcircuits follows.

Figure 2 shows a circuit diagram of the analog time shifter. The time constant of the input integrator (R_T , C_1) modifies the input waveform slope and consequently the time when T_1 turns on. The output of this switching circuit is a square waveform with the time delay, which is controlled by adjusting the value of R_T .

However, the repeatability of accurately setting R_T is poor using the analog circuit described above, and the absolute range of realizable time shifts is also considerably limited. These

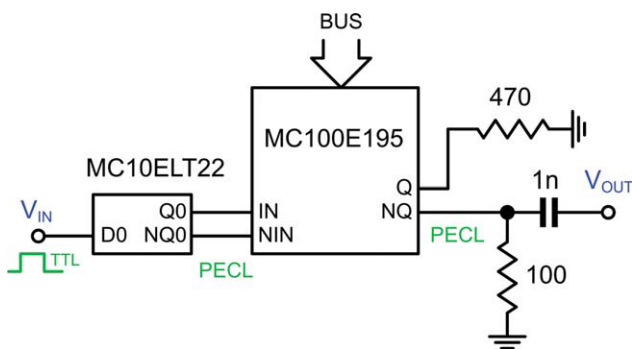

Figure 3 Digital time shifter. [Color figure can be viewed in the online issue, which is available at wileyonlinelibrary.com]

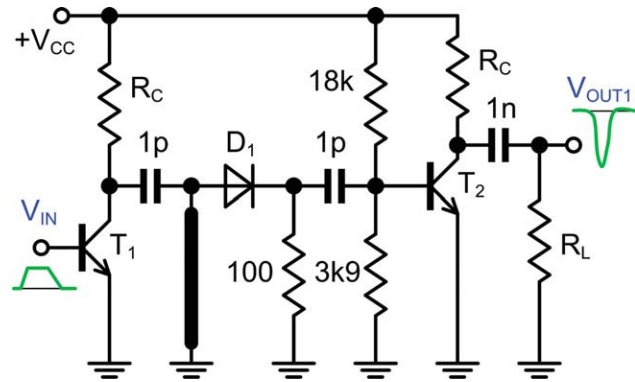

Figure 4 Simplified circuit diagram of the Gaussian pulser. [Color figure can be viewed in the online issue, which is available at wileyonlinelibrary.com]

issues are well accomplished by the digital time shifter, which is depicted in Figure 3. It is based on the programmable time delay chip MC100E195 (ON Semiconductor), which provides 2 ns maximum delay range with a digitally-selectable resolution of ~ 20 ps. MC10ELT22 translates TTL levels to differential PECL (positive ECL), which is required by the delay chip. The output translator is omitted, and the inverting node of the differential-output was only used to trigger subsequent circuits.

Various Gaussian pulsers may be utilized in our experimental design. To avoid using expensive solid-state components such as step recovery diodes, we selected a low cost transistor solution. A simplified circuit diagram is shown in Figure 4.

T_1 (BFG410W) supplies a negative voltage step with a leading edge rise time of about 300 ps to the following derivative circuit, which consists of a coupling capacitor and a short-circuited microstrip stub. The resulting waveform has the character of a high-order derivative of a Gaussian pulse. D_1 (BAT15-03W) removes the negative part of the waveform and the operating point of the subsequent stage is set in such a way that T_2 (BFG410W) selectively amplifies the pulse with the highest positive amplitude. Since T_2 operates as an inverting amplifier, the output pulse V_{OUT1} , which is shown in Figure 6, is negative. The pulse was measured using an Agilent 86100C sampling oscilloscope. The maximum amplitude of this pulse

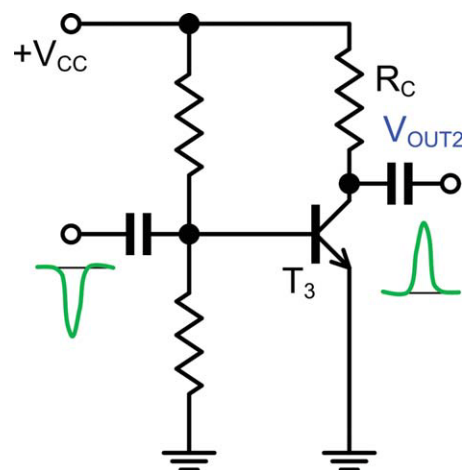

Figure 5 Simplified circuit diagram of the pulse inverter. [Color figure can be viewed in the online issue, which is available at wileyonlinelibrary.com]

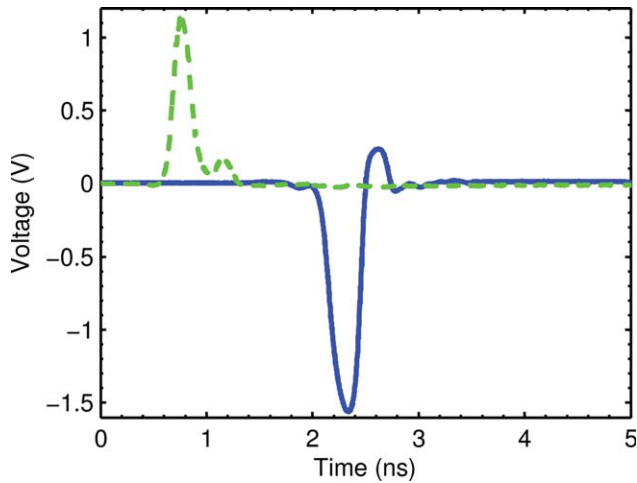

Figure 6 Measured negative output pulse V_{OUT1} generated by the circuit shown in Figure 4 (continuous line). Measured positive output pulse V_{OUT2} of the Gaussian pulser with an additional inverting stage shown in Figure 5 (dashed line). [Color figure can be viewed in the online issue, which is available at wileyonlinelibrary.com]

reaches -1.6 V, and it has an full-width at half-maximum (FWHM) of about 300 ps. The measurement was carried out at 8 MHz pulse repetition frequency, but the dependence of the pulse shape on the triggering frequency is negligible. The circuit is supplied by $V_{CC} = 5$ V.

To generate a positive Gaussian pulse, an additional inverting stage may be connected to the output of the negative pulser, as shown in Figure 5. The resulting output waveform V_{OUT2} is shown in Figure 6. The pulse is 1.1 V in amplitude and it has an FWHM of 175 ps.

The last important part of the proposed UWB generator is a pulse combiner. Pulse combiners are usually designed as band-pass structures, which significantly distort baseband Gaussian pulses. A possible solution to this issue is provided by the structure shown in Figure 7. A particular challenge concerning the design of similar structures is how to deal with the ringing that arises from the discontinuity formed by multiple interconnected

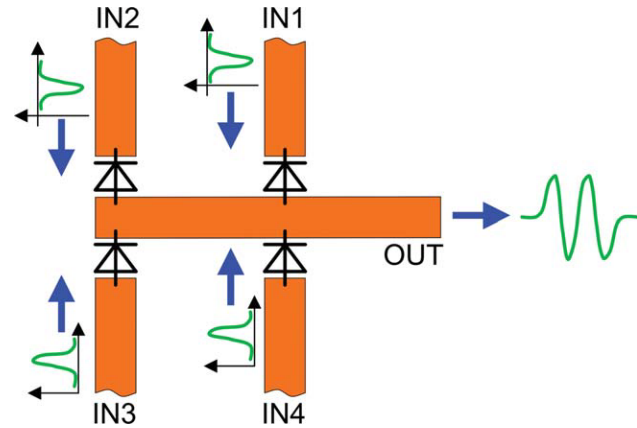

Figure 7 Layout of the UWB pulse combiner with isolated inputs. This structure sums two positive and two negative Gaussian pulses. [Color figure can be viewed in the online issue, which is available at wileyonlinelibrary.com]

transmission lines. In the case of combining unipolar Gaussian pulses, Schottky diodes can provide a sufficient level of isolation, as indicated in Figure 7.

3. DESIGN EXAMPLES

To demonstrate the performance of the pulse combining technique, two experimental generators have been designed. The first generator is assembled from two positive Gaussian pulsers and one negative Gaussian pulser, the triggering of which is controlled by analog time shifters manually adjustable by potentiometers. Figure 8 shows a block diagram of the proposed generator. This generator is suitable for generating complex UWB waveforms with a fixed shape.

A good example of a generated UWB pulse is given in Figure 9. Its time domain shape corresponds to the second derivative of the Gaussian pulse, which is referred to as a Gaussian doublet. The pulse is 0.85 V in peak-to-peak amplitude and it is ~ 580 ps in full width. The frequency domain representation of this pulse, calculated using the Fourier transform, is shown in Figure 10.

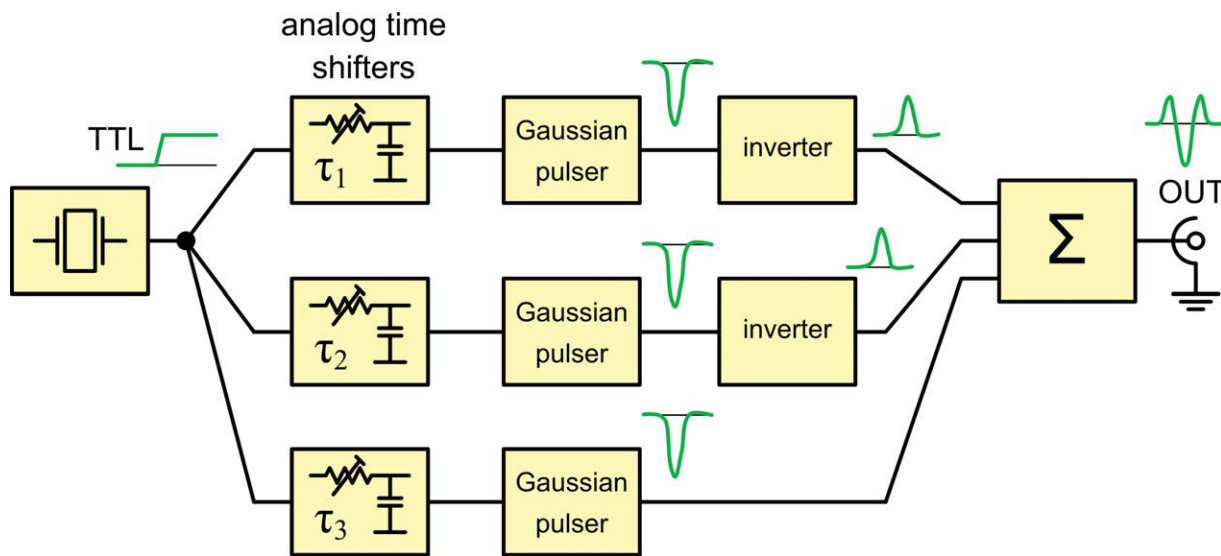

Figure 8 The first experimental generator is composed of two positive and one negative Gaussian pulser and analog time shifters. [Color figure can be viewed in the online issue, which is available at wileyonlinelibrary.com]

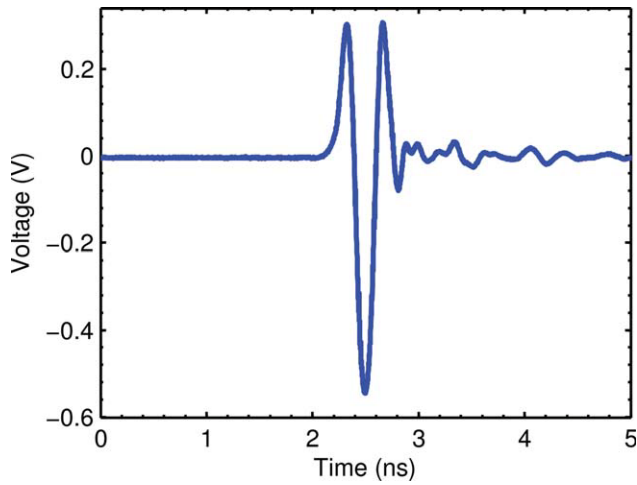

Figure 9 Measured Gaussian doublet generated by the first experimental board. [Color figure can be viewed in the online issue, which is available at wileyonlinelibrary.com]

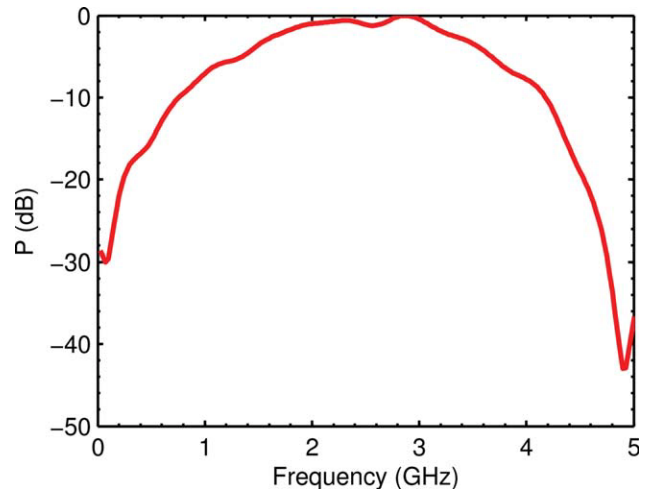

Figure 10 Power spectrum of the Gaussian doublet from Figure 9, normalized to the peak value. [Color figure can be viewed in the online issue, which is available at wileyonlinelibrary.com]

As already mentioned in section 2, analog time shifters suffer from several disadvantages. Therefore, our second design utilizes more flexible digital time shifters programmable via a PC. A block diagram is shown in Figure 11. It consists of four identical Gaussian pulsers with their outputs collected by the pulse combiner based on the layout shown in Figure 7. To increase the output power, T_2 (BFG410W) was changed to BFP540 in each pulser, which is capable of driving higher current to a load.

The shape of the resulting combined waveform was additionally modified by a transmission line first-order differentiator consisting of a short-circuited stub [8]. The measured response of this pulse forming network to a Gaussian pulse excitation is shown in Figure 12. This pulse shape is called a Gaussian monocycle. It is 2.5 V in peak-to-peak amplitude and ~ 800 ps in full width. Its power spectrum is shown in Figure 13.

Employing all Gaussian pulsers with different triggering delays offers a wide range of possible output waveform shapes and corresponding spectral properties. Figure 12 shows an example of a waveform combined from four identical monocycles generated with linearly increasing delay. The impact of this particular pulse shaping on the waveform properties in the frequency domain is demonstrated by Figure 13. By controlling the digital time shifters and/or by switching the trigger of a selected Gaussian pulser on and off, the circuit can operate as a transmitter with transmitted-reference (TR) or pulse position modulation [3].

4. CONCLUSION

In this article, we have presented a method of UWB pulse waveform design which is based on combining Gaussian pulses from multiple sources. The flexibility of this technique for modifying the output waveform shape and simultaneously its spectral

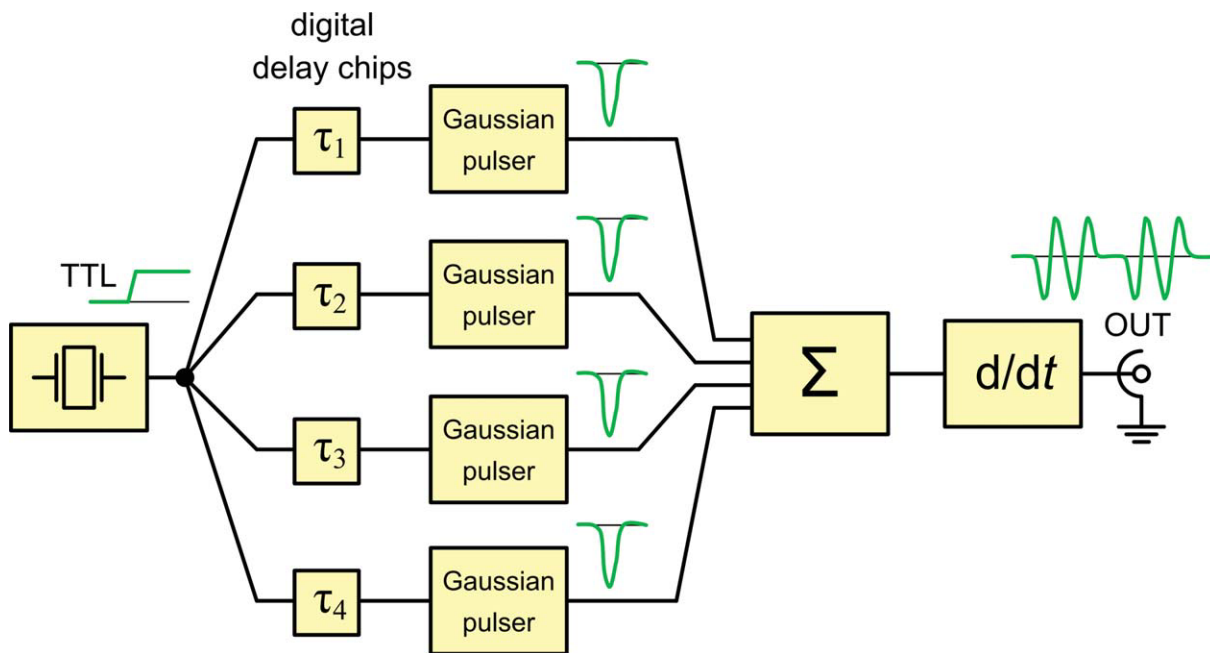

Figure 11 Experimental generator with four identical Gaussian pulsers and digital time shifters. [Color figure can be viewed in the online issue, which is available at wileyonlinelibrary.com]

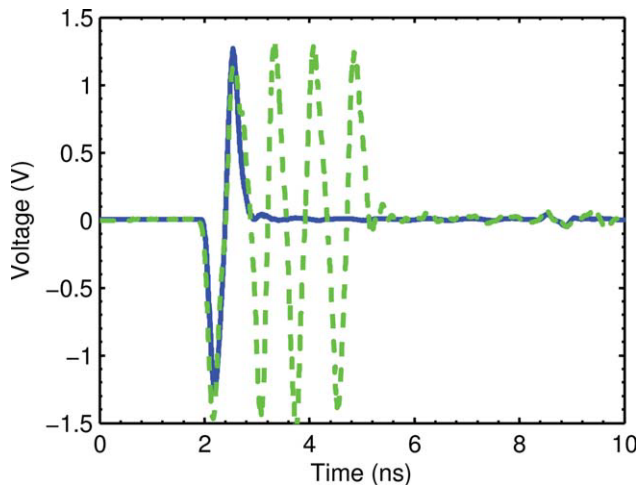

Figure 12 Measured Gaussian monocycle generated by the second experimental board. Only one of four Gaussian pulsers was triggered in this configuration (continuous line). A UWB waveform combined from four identical pulses separated by a constant delay (dashed line). [Color figure can be viewed in the online issue, which is available at wileyonlinelibrary.com]

properties was demonstrated by two generator design examples. Both designs were implemented and their properties were measured by a wideband oscilloscope. The first generator was equipped with analog time shifters, whereas the other generator utilized digitally programmable delay chips to adjust the timing of the initial Gaussian pulses to be combined. The generator with analog time shifters was used to generate a complex UWB waveform with a fixed shape. Digital time shifters work with limited resolution. However, the high delay range and digital control provide greater flexibility. The pulse combining principle together with the application of digitally controlled time shifters can form the basis for a transmitter in the UWB system with TR modulation.

ACKNOWLEDGMENTS

This work was supported by the Ministry of Defence of the Czech Republic under project 080187090 “LOCALIZATION—System

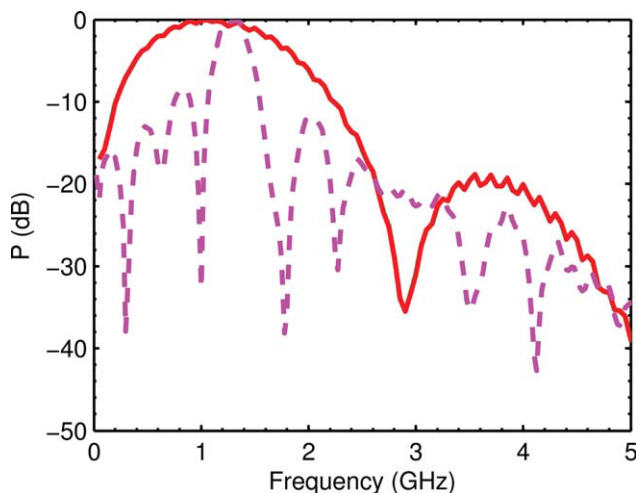

Figure 13 Frequency spectrum of the Gaussian monocycle (continuous line). Power spectrum of the UWB waveform from Figure 11 (dashed line). [Color figure can be viewed in the online issue, which is available at wileyonlinelibrary.com]

detection and localization of protected moving and stationary object trespasser” with further support from the Grant Agency of the Czech Republic under project GD102/08/H018 “Modelling and simulation of fields.”

REFERENCES

1. N. Paulino, J. Goes, and A.S. Garcao, *Low power UWB CMOS radar sensors*, Springer, 2008.
2. H. Arslan, Z.N. Chen, and M.-G. Di Benedetto, *Ultra wideband wireless communication*, Wiley, Hoboken, NJ, 2006.
3. K. Siwiak and D. McKeown, *Ultra-wideband radio technology*, Wiley, Hoboken, NJ, 2004.
4. J.H. Reed, *An introduction to ultra wideband communication systems*, Prentice Hall PTR, Upper Saddle River, NJ, 2005.
5. D. Daniels, *Ground penetrating radar*, IEE, London, UK, 2004.
6. M.J.W. Rodwell, S.T. Allen, R.Y. Yu, M.G. Case, U. Bhattacharya, M. Reddy, E. Carman, M. Kamegawa, Y. Konishi, J. Pusi, and R. Pullela, *Active and nonlinear wave propagation devices in ultrafast electronics and optoelectronics*, *Proc IEEE* 82 (1994), 1037–1059.
7. P.W. Smith, *Transient electronics: Pulsed circuit technology*, Wiley, Hoboken, NJ, 2002.
8. P. Protiva, J. Mrkvica, and J. Macháč, *Universal generator of ultra-wideband pulses*, *Radioengineering* 17 (2008), 74–78.
9. C.-W. Hsue, L.-C. Tsai, and K.-L. Chen, *Implementation of first-order and second-order microwave differentiators*, *IEEE Trans Microwave Theory Tech* 52 (2004), 1443–1448.
10. J. Han and C. Nguyen, *On the development of a compact sub-nanosecond tunable monocycle pulse transmitter for UWB applications*, *IEEE Trans Microwave Theory Tech* 54 (2006), 285–293.
11. C. Zhang and A.E. Fathy, *Reconfigurable pico-pulse generator for UWB applications*, *Proc IEEE MTT-S Int Microwave Symp Digest*, San Francisco, CA (2006), 407–410.
12. J. Han and C. Nguyen, *A new ultra-wideband, ultra-short monocycle pulse generator with reduced ringing*, *IEEE Microw Wirel Co* 12 (2002), 206–208.
13. P. Protiva, J. Mrkvica, and J. Macháč, *Sub-nanosecond pulse generator for through-the-wall radar application*, *Proc Eur Microwave Week 2009*, 4 pp.
14. C. Fang, C.L. Law, and J. Hwang, *High-voltage high-efficiency ultra-wideband pulse synthesizer*, *IEEE Microw Wire Co* 20 (2010), 49–51.
15. S.B. Cohn, *A class of broadband three-port TEM-mode hybrids*, *IEEE Trans Microwave Theory Tech* 19 (1968), 110–116.
16. A.M. Abbosh, *Multilayer inphase power divider for UWB applications*, *Microw Opt Techn Lett* 50 (2008), 1402–1405.
17. A.M. Abbosh, *Design of ultra-wideband three-way arbitrary power dividers*, *IEEE Trans Microwave Theory Tech* 56 (2008), 194–201.
18. K. Song and Q. Xue, *Novel ultra-wideband (UWB) multilayer slot-line power divider with bandpass response*, *IEEE Microw Wirel Co* 20 (2010), 13–15.

© 2010 Wiley Periodicals, Inc.

NOVEL PLANAR TRIPLE BAND MONOPOLE ANTENNA FOR WiMAX/WLAN Applications

Hsien-Wen Liu¹ and Chia-Hao Ku²

¹Department of Electrical Engineering, National Taiwan University of Science and Technology, Taipei, Taiwan, Republic of China; Corresponding author: D9407303@mail.ntust.edu.tw

²Department of Electrical Engineering, Ming Chi University of Technology, Taipei, Taiwan, Republic of China

Received 29 January 2010

ABSTRACT: A coplanar waveguide (CPW)-fed planar monopole antenna with triple band operation for worldwide interoperability for microwave access (WiMAX) and wireless local area network (WLAN)