

50 μm core. The quality of image and sound was very good in all channels. Due to the higher signal loss and low laser power the optimum modulation indices were around 8...10%, which is roughly a triple the values encountered in CATV systems. The high-transmission loss in MM fiber limits the number of transmitted channels. This restriction may be overcome using lasers with greater optical powers. Moreover, these limitations are much relaxed for the transmission of digital video signals, whose requirements for CNR and nonlinearities are not so strict.

REFERENCES

1. C. Xia, M. Ajaonkar, W. Rosenkranz, On the performance of the electrical equalization technique in MMF links for 10-Gigabit Ethernet, *IEEE J Lightwave Technol* 23 (2005), 2001–2011.
2. A.M. Diab, J.D. Ingham, R.V. Penty, and I.H. White, Statistical analysis of subcarrier-modulated transmission over 300 m of 62.5 μm -core-diameter multimode fiber, *IEEE J Lightwave Technol* 23 (2005), 2380–2398.
3. A.M. Diab, J.D.F. Ingham, R.V. Penty, and I.H. White, 10 Gb/s transmission on single-wavelength multichannel SCM-based FDDI-grade MMF links at lengths over 300 m: A statistical investigation, *IEEE J Lightwave Technol* 25 (2007), 2976–2983.
4. J. Siuzdak, G. Stepniak, L. Maksymiuk, A 2 and 3 channel mode group diversity multiplexing transmission over graded and step index multimode fibers, *ECOC 2008, Brussel, 2008, Vol. 3, WE 3F. 6*.
5. N. Guan, K. Takenaga, S. Matsuo, and K. Himeno, Multimode fibers for compensating intermodal dispersion of graded-index multimode fibers, *IEEE J Lightwave Technol* 22 (2004), 1714–1719.
6. H. Taylor and S.W. Golomb, *Rulers-Part 1: CSI Technical Report 85-05-01*, Communication Science Institute, University of Southern California, Los Angeles, CA, 1985.

© 2009 Wiley Periodicals, Inc.

A COMPACT STEP RECOVERY DIODE SUBNANOSECOND PULSE GENERATOR

Pavel Protiva,¹ Jan Mrkvička,² and Jan Macháč¹

¹Department of Electromagnetic Field, Faculty of Electrical Engineering, Czech Technical University in Prague, Technická 2, 166 27 Praha 6, Czech Republic; Corresponding author: protip1@fel.cvut.cz

²RETIA, a.s., Pražská 341, Zelené Předměstí, Pardubice 530 02, Czech Republic

Received 27 May 2009

ABSTRACT: A compact Ultra-Wideband subnanosecond pulse generator is described in this article. The fundamental part of the generator consists of a step recovery diode (SRD), which works as a waveform edge sharpener. The SRD is included in a compact pulse-forming network, which is used to form a narrow Gaussian pulse. The proposed circuit solution utilizes the performance of the SRD effectively with minimal requirements regarding the driver stage of the generator. The measurements show the waveform and power spectrum of the Gaussian pulse that is generated.

© 2009 Wiley Periodicals, Inc. *Microwave Opt Technol Lett* 52: 438–440, 2010; Published online in Wiley InterScience (www.interscience.wiley.com). DOI 10.1002/mop.24945

Key words: Ultra-wideband; pulse generator; Gaussian pulse; step recovery diode; pulse-forming network

1. INTRODUCTION

An ultra-wideband (UWB) subnanosecond pulse generator is the main component of many transmitting and also receiving UWB systems. Various techniques are used to generate UWB pulses. A conventional short pulse generator consists of an edge sharp-

ener, which sharpens and accelerates a slow rise time driving waveform edge, and a pulse-forming network, which forms the output pulse to the desired shape.

Special solid-state components are commonly utilized as pulse sharpeners. Avalanche transistors, step recovery diodes (SRD) [1], tunnel diodes [2], bipolar transistors [3], and FETs [4] are used. Avalanche transistors are advantageous as high-power sharpeners, but the maximal usable pulse repetition frequency and the transistor lifetime are limited. Tunnel diodes offer the shortest transition times at very small amplitudes. The SRD is a compromise alternative to these components and is capable of generating pulses with ~ 50 – 150 ps transition time. This makes them most preferred for current UWB applications. The theory and application of SRDs in edge sharpening circuits is well described elsewhere [5].

A pulse-forming network converts the step-like waveform generated by the SRD sharpener to a Gaussian-like or some other pulse form that is required for a specific application. Transmission line pulse-forming networks [6] or simple RC-differentiators [7] are most frequently used. Complex planar structures, such as coupled-line couplers [8], are also reported to exhibit usable pulse-forming properties. However, any circuits connected to the output of the SRD sharpener introduce an insertion loss and inevitable ringing into the output waveform. Therefore, additional circuits have to be used to suppress ringing [9]. The main constraint of the SRD pulse generator design is the limited minimum pulse width of the generated pulse, which is determined by the parameters of the SRD. Consequently, SRDs are primarily used for lower UWB bands up to about 5 GHz. The output pulse width and amplitude can be improved using MESFET amplification and compression circuits [10]. Unfortunately, the low maximum drain-source voltage of active forming circuits limits the output pulse amplitude.

This article describes a UWB subnanosecond generator. The basis of the generator is an SRD, which works as a standard waveform edge sharpener connected in parallel with a transmission line. However, the sharpener is included in a unique pulse-forming network consisting of a Schottky diode and a delay line. Our solution has many advantages. In our previous article [11], we used a similar structure to generate stable high-amplitude pulses independent of the pulse repetition frequency. In this article, we present a pulse-forming network with an improved topology, which is capable of generating narrow Gaussian pulses to increase the bandwidth of the generator. Our second objective was to maintain a low-ringing level. The measurement results show that both requirements are fulfilled without the need for additional ringing reduction or active pulse compression circuits.

2. CIRCUIT DESCRIPTION AND DESIGN

A circuit diagram of the proposed generator is shown in Figure 1. The first part of the generator (TTL inverter, R_1 , C_1 , R_2 , C_2 , T_3) is a simple edge triggered timing circuit, which generates a well-defined pulse to be supplied to the driver. The pulse width is adjustable down to a few nanoseconds by R_2 and is independent of the input TTL waveform frequency and duty cycle. The function of the timing circuit is described in detail elsewhere [11].

The following stage of the generator, a transistor driver (T_1 , T_2 , R_3 , R_4 , C_3), generates a negative voltage pulse with sufficient power and speed to drive an SRD. We selected the MMBT3904 and the BFG591 bipolar transistors for the first and second stage of the driver, respectively. The selected circuit topology, where T_1 operates as common-collector and T_2 as

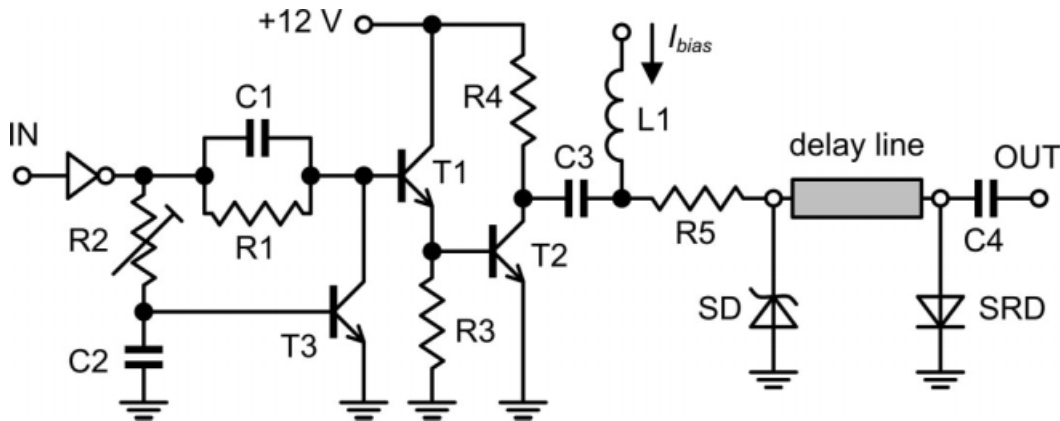

Figure 1 Circuit diagram of the proposed Gaussian pulse generator

common-emitter switch, generates a negative driving pulse with a fast leading edge (hundreds of picoseconds) while the trailing edge is relatively slow (a few nanoseconds).

The third stage of the generator consists of an SRD sharpener and a Gaussian pulse-forming network. The purpose of the SRD sharpener is to sharpen the leading edge of the driving pulse. The sharpened step-like pulse is then processed in a pulse-forming network.

When no driving pulse is present, the SRD is forward biased by a constant bias current. A Schottky diode (SD) is reverse biased and does not influence the circuit. After triggering the generator input, the driver generates a driving pulse, which passes through the coupling capacitor C_3 (10 nF), the damping resistor R_5 (4.7 Ω), and the delay line to the SRD. After the SRD turns off, a fast falling edge voltage step propagates in both directions away from the SRD. The first step propagates unchanged through a coupling capacitor C_4 (10 pF) to the output, whereas the second propagates along the delay line back to the input. However, the shunt-connected Schottky diode is now opened by the negative driving pulse sufficiently to short-circuit the transmission line. Therefore, the incoming step waveform is reflected back with an inverted polarity. It propagates to the output again, where it contributes to the output waveform. By summing the delayed inverted step with the unchanged forward waveform, a Gaussian-like pulse is formed. After a few nanoseconds, the driver turns off and the circuit returns to the steady state.

This unconventional circuit solution, where the pulse-forming network precedes the SRD sharpener in the signal chain, is capable of forming reasonably high-amplitude pulses with low-

ringing levels. The ringing level can be further reduced by increasing R_5 .

The RF part of the generator was designed by the AWR Microwave Office design suite. The final layout is shown in Figure 2. The pulse generator was implemented on an ARLON AD450 substrate 0.762 mm in thickness. We used the MA44621A SRD in the ODS-93 package [12] and the MA4E190 Schottky diode in the ODS-276 package, both manufactured by MA-COM. The cylindrical form of the ODS packages enables the diodes to be mounted directly in through-holes 1.3 mm in diameter. The leads of the diodes are then soldered directly to the bottom ground plane without the need for additional vias. This particular form of the pulse-forming network is optimal for generating very short Gaussian pulses.

The delay line between SRD and the Schottky diode was implemented as a section of a microstrip line 4 mm in length (L) and with a characteristic impedance of about 90 Ω . The correct width was obtained by optimization in the AWR simulator.

3. EXPERIMENTAL RESULTS AND DISCUSSION

First, the timing circuit and the driver of the generator were measured, with C_3 terminated by a 50 Ω load. A TTL square waveform with a repetition frequency of 5 MHz was used to trigger the generator input. However, any frequency up to

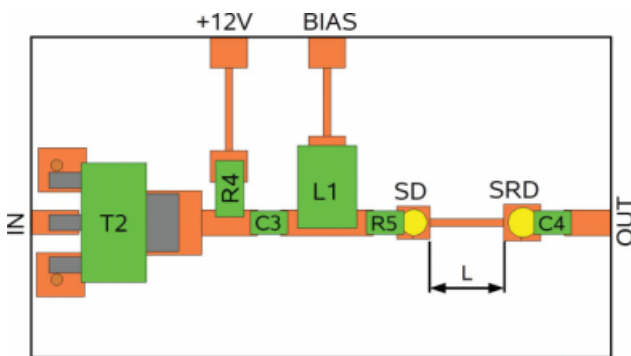

Figure 2 Layout of the pulse-forming network. [Color figure can be viewed in the online issue, which is available at www.interscience.wiley.com]

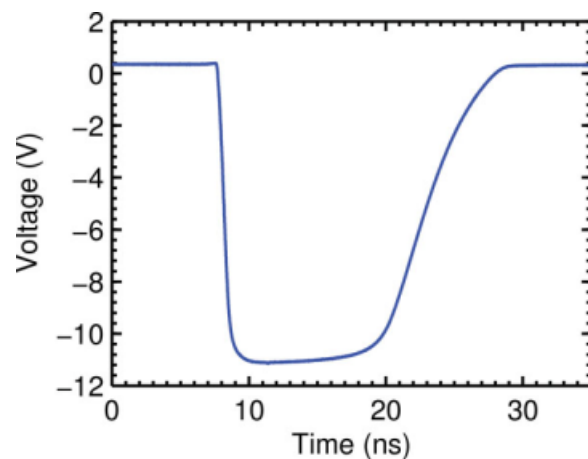

Figure 3 Measured output waveform of the driver. [Color figure can be viewed in the online issue, which is available at www.interscience.wiley.com]

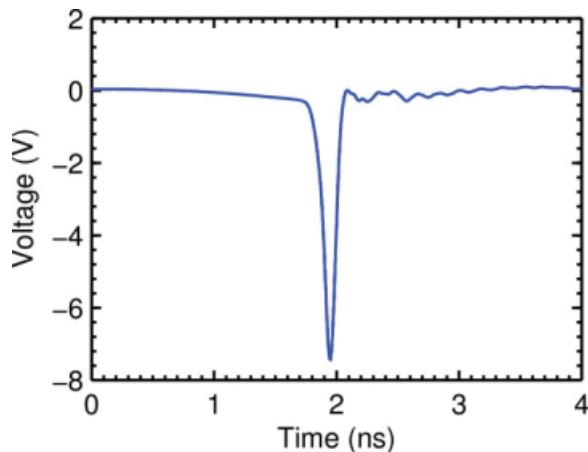

Figure 4 Measured output waveform of the pulse generator. [Color figure can be viewed in the online issue, which is available at www.interscience.wiley.com]

10 MHz is applicable without notable influence on the shape of the output pulse.

Figure 3 shows the output waveform of the driver measured with a wideband oscilloscope. This negative driving pulse is -11.5 V high at 12 V power supply voltage. The leading edge fall time of this pulse is ~ 800 ps, which is sufficiently short to drive the SRD. By contrast, the trailing edge of the driving pulse is slower and smoother. Therefore, it does not introduce any overshoots and distortions into the output waveform. To minimize the current consumption of the driver and the power dissipation of the Schottky diode, we set the driving pulse width to a small value of ~ 15 ns, as shown in Figure 3.

The output waveform of the complete pulse generator was measured using an Agilent 86100C sampling oscilloscope at a 50Ω load. A 30 mA constant current from an external source was used to bias the SRD. A measured Gaussian pulse is plotted in Figure 4. The maximum amplitude of this pulse reaches -7.5 V, and the pulse has an FWHM (Full-Width at Half-Maximum) of about 110 ps. A lower FWHM is obtainable by shortening the delay line length; however, the pulse output amplitude decreases. The ringing level does not exceed 5% of the output amplitude.

The power spectrum of the pulse from Figure 4 calculated using the Fourier transform is shown in Figure 5, normalized to

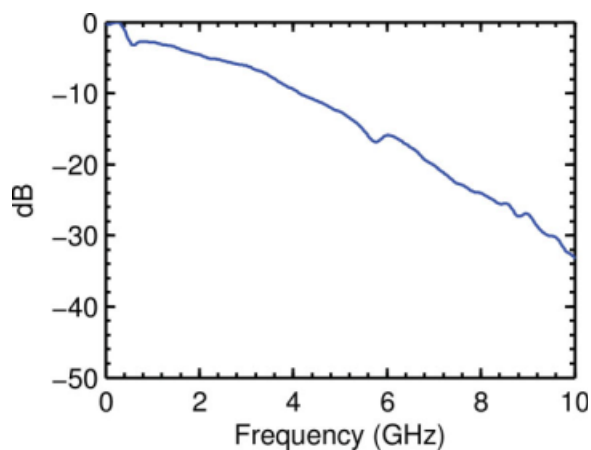

Figure 5 Calculated power spectrum of the output Gaussian pulse normalized to the maximum value. [Color figure can be viewed in the online issue, which is available at www.interscience.wiley.com]

the maximum value. The 20 dB pulse bandwidth is 7 GHz, which is almost twice the bandwidth of the pulses presented elsewhere [11].

4. CONCLUSIONS

In this article, we have presented a new circuit solution of an UWB subnanosecond pulse generator. A Gaussian pulse is generated by a SRD sharpener, which is included in a unique pulse-forming network consisting of a Schottky diode and a delay line. The location of the pulse-forming network in the input section of the SRD sharpener provides high-output amplitudes and maintains a low-ringing level. We also designed a two-stage transistor driver, which does not introduce any unwanted distortion into the output pulse. The measurement results prove that our circuit solution is capable of generating narrow Gaussian pulses without the need for additional pulse compression circuits. The pulse generator concept presented here has been successfully applied in UWB transmitters and as a part of microwave sampling circuits.

ACKNOWLEDGMENTS

The circuit design and simulation have been supported by the Grant Agency of the Czech Technical University in Prague under project CTU 0903513 "Propagation of UWB signals" with further support from the Grant Agency of the Czech Republic under project GD102/08/H018 "Modelling and simulation of fields." The components for constructing, setting up, and measuring the transmitter have been supported by the Ministry of Industry and Trade of the Czech Republic under project FI-IM5/090 "Ultrawideband Radar and Positioning Systems."

REFERENCES

1. J.D. Taylor, Ultra-wideband radar technology, CRC Press, Boca Raton, FL, 2001.
2. E.K. Miller, Time-domain measurements in electromagnetics, Springer, New York, NY 1986.
3. M. Gerding, T. Musch, and B. Schiek, Generation of short electrical pulses based on bipolar transistors, *Adv Radio Sci* 2 (2004), 7–12.
4. A. Ouslimani, G. Vernet, H. Hardallah, and R. Adde, Large amplitude picosecond step generation with FETs, *Electron Lett* 26 (1990), 1563–1564.
5. Hewlett-Packard, Hewlett-Packard application note AN918: Pulse and waveform generation with step recovery diodes, Hewlett-Packard, Palo Alto, CA 1968.
6. C. Hsue, L. Tsai, and K. Chen, Implementation of first-order and second-order microwave differentiators, *IEEE Trans Microwave Theory Tech* 52 (2004), 1443–1448.
7. J.H. Reed, An introduction to ultra wideband communication systems, Prentice Hall PTR, 2005.
8. E. Maxwell, T. Weller, and E. Odu, Design and analysis of a multiport circuit for shaping sub-nanosecond pulses, *IEEE Trans Microwave Theory Tech* 56 (2008), 2764–2770.
9. J. Han and C. Nguyen, A new ultra-wideband, ultra-short monocyte pulse generator with reduced ringing, *IEEE Trans Microwave Theory Tech* 50 (2002), 206–208.
10. M. Miao and C. Nguyen, A uniplanar picosecond impulse generator based on MESFET and SRD, *Microwave Opt Technol Lett* 39 (2003), 470–472.
11. P. Protiva, J. Mrkvica, and J. Macháč, Universal generator of ultra-wideband pulses, *Radioengineering* 17 (2008), 74–78.
12. MA43000, MA44600 Series Silicon Step Recovery Diodes, MA-COM Technical Solutions, Available at http://www.macom.com/DataSheets/-MA43000_MA44600%20Series.pdf.