

RADIATION FROM THE CONDUCTOR-BACKED SLOTLINE

J. Machac, J. Zehentner

Czech Technical University, Technicka 2, 16627 Prague 6, Czech Republic

Abstract: The conductor-backed slotline radiates when the CPW feeder excites the 1st space leaky wave on the line. One main beam features the radiation pattern of this planar radiator. The leaky wave antenna on the conductor-backed slotline was designed, fabricated and measured. The modified version of the this line has an additional dielectric layer placed on the top surface of the original structure where the slot is located. This layer modifies the dispersion characteristics of the waves. The choice of its parameters influences the width of the frequency band or reduces/enhances the scanning sensitivity of the main beam.

INTRODUCTION

Modern microwave and millimeter wave circuits are based on planar technology. Transmission lines such as the coplanar waveguide (CPW), coplanar strips (CPS) and the slotline (SL), are the main building blocks of these circuits. Conductor backing drastically changes the behaviour of the lines. The conductor-backed CPW (CBCPW) and the conductor-backed slotline (CBSL) are not able to transmit a bound wave. Measures for ensuring bound mode propagation on CBCPW have been studied [1]. On the other hand these lines can be used as radiating elements – leaky wave antennas. They possess the advantages of the planar arrangement and like traveling wave antennas they are able to radiate effectively in a wide frequency band. Due to the conductor backing they radiate into the main lobe directed above the structure.

The beam radiated by the leaky wave antenna is steered by the frequency change. The sensitivity of the frequency scanning can enhance a line with a steep dispersion characteristic. On the other hand, a mode with a flat dispersion characteristic is exploited for an antenna radiating in the specific direction independently of the frequency variation. The modified conductor-backed slotline (MCBSL) leaky wave antenna can meet these requirements. In contrast to the traditional conductor-backed slotline, the additional dielectric layer, the thickness and permittivity of which can be varied, adjusts the dispersion characteristic of the line correspondingly.

CBSL ANTENNA

The cross-section of the CBSL is shown in Fig. 1a. This line supports the dominant mode, which can propagate from zero frequency [3]. Unfortunately this mode is not a bound mode. It has the character of a standing wave in the transversal x direction in a substrate with double sided metallization. Consequently this line is not suitable for signal transmission. If the slot is wide enough, the CBSL can support the propagation of space leaky modes with odd symmetry of the transversal electric field component E_x in the slot. The dispersion characteristic of the 1st order space leaky mode is plotted in Fig. 2. The mode is physical in the frequency band in which the phase constant is lower than k_0 , the propagation constant in free space. The leaky constant reaches very high values at low frequencies. This does not imply high radiation efficiency. The applicable frequency band starts at higher frequencies, where the attenuation constant has a reasonably low value, roughly at the frequency where the phase constant falls to its minimum. The usable frequency band of radiation of a line with the parameters from Fig. 2 is confined to 3.5 – 6.25 GHz. This frequency band is reduced further by the antenna CPW feeder which excites modes with odd symmetry of the transversal electric field component E_x , Fig. 3a. The feeder was optimized by the Microwave Studio Simulator in order to get the widest possible frequency band. The calculated and measured return losses of the antenna are plotted in Fig. 4. The antenna effectively radiates when the return losses are lower than -10 dB, i.e., from 4.75 GHz to 6 GHz, the corresponding frequency band is about 23%.

The form of the radiation pattern can be optimized to some extent by the geometry of the slot termination. The antenna radiation pattern is plotted in Fig. 5. Angles $\theta=0$ and 90 deg, Fig. 3b, correspond to radiation perpendicularly above the substrate and in the forward direction, respectively. The antenna radiates into one lobe, the direction of which changes with frequency. The maximum of the radiation intensity tilts with increasing frequency to the substrate surface from $\theta=37$ to 70 deg at 4.75 GHz and 6 GHz, respectively. The corresponding scanning sensitivity is about 26 deg/GHz. The measured -3dB widths of the radiation pattern are 46.7 deg at 4.75 GHz, 36.7 deg at 5.25 GHz and 32.8 deg at 6 GHz. Radiation below the substrate also occurs due to the finite dimensions of a substrate with back metallization. The level of this radiation increases with frequency from -35 dB below the main beam level at 4.75 GHz and -30 dB at 5.25 GHz, to about -25 dB at 6 GHz.

RADIATION OF THE MCBSL

The cross-section of the MCBSL is shown in Fig. 1b. The additional upper dielectric layer offers two additional parameters controlling the dispersion characteristics. Fig. 6 shows the dependence of the dispersion characteristics of the 1st space leaky mode on the MCBSL on the thickness of the upper dielectric layer h_2 . The permittivity of the substrate and the layer is 2.6. The characteristic in the case of a thin upper layer naturally resembles the characteristic from Fig. 2. For thicker upper layers, e.g., $h_2=5$ mm in Fig. 6, the dispersion characteristic is steep and provides a narrower usable frequency band. Therefore this MCBSL is suitable for an antenna with high scanning sensitivity. The dispersion characteristic in Fig. 6 becomes relatively flat at higher frequencies with a further increase of thickness h_2 , e.g., to $h_2=10$ mm. Such a line is a candidate for the wide band antenna with a radiation pattern less sensitive to frequency variation. For an even thicker upper layer the frequency band shrinks again. The increase of the upper dielectric layer permittivity shifts the dispersion characteristic to lower frequencies and makes it steeper, and the usable frequency band narrows.

An MCBSL antenna with reduced width of the upper dielectric layer, Fig. 1c, possesses a smoother radiation pattern than an antenna with the same width of the two dielectric layers. The radiation of this MCBSL antenna when $h_2=10$ mm, $b_1=70$ mm and $b_2=31$ mm is shown in Fig. 7. The main lobe moves slightly with the frequency. Its scanning sensitivity is 13 deg/GHz within the frequency band from 4 to 5 GHz. The calculated scanning sensitivity of the main beam of an MCBSL antenna with the parameters defined in Fig. 6 with the same width of the upper and lower layer, Fig. 1b, and with $h_2=5$ mm is 40 deg/GHz. Fig. 8 shows the radiation patterns of the MCBSL antenna with the cross-section in Fig. 1c, where $h_2=5$ mm and $b_2=31$ mm. The main lobe scanning sensitivity is now 24 deg/GHz, within the frequency band from 4 GHz to 5 GHz. This is less than for an antenna having the same width of the upper and lower layer, the radiation pattern of which is not suitable for practical applications due to its strong ripple. The measured patterns plotted in Figs. 7 and 8 fit the calculated patterns well.

CONCLUSIONS

The conductor-backed slotline is a suitable radiating element – a leaky wave antenna which radiates into one main lobe above the substrate. However there is some radiation below the substrate due to the finite size of the antenna. The antenna design is based on the dispersion characteristics of the 1st order space leaky mode. The antenna, fed by the CPW, was designed, fabricated and measured. Short-circuited termination of the slot in the shape of a wedge reduces the radiation pattern ripple and back lobes. Frequency scanning sensitivity 26 deg/GHz was achieved in the 4.75-6.0 GHz range. The measured and calculated radiation patterns as well as the input return loss compare well. The effective operation frequency band of the antenna defined by $S_{11} < -10$ dB is from 4.75 to 6 GHz, i.e., 23 %.

The modified conductor-backed slotline enables more flexible antenna design. The upper dielectric layer thickness and permittivity change the dispersion characteristics of the 1st space leaky mode. This antenna possesses either increased beam scanning sensitivity or a radiation pattern that is less sensitive to the frequency change. The latter has a wider operation frequency band.

REFERENCES

- [1] Y. Liu, K. Cha, T. Itoh: Non-leaky coplanar (CNL) waveguides with conductor backing, IEEE Trans. Microwave Theory and Techn., Vol. 43, No. 5, May 1995, pp.1067-1072.
- [2] J. Zehentner, J. Machac, J. Mrkvica: Novel selected modes on the conductor-backed slotline, 2002 IEEE MTT-S International Microwave Symposium Digest, Seattle, June 2002, Vol. 2, pp. 961-964.
- [3] J. Zehentner, J. Machac, J. Mrkvica, C. Tuzi: The inverted conductor-backed slotline – a challenge to antenna and circuit design. Proc. of the 33rd European Microwave Conference, Munich, Germany, October 2003, Vol. 1, pp. 73-76.

ACKNOWLEDGEMENT

This work has been supported by the Grant Agency of the Czech Republic under project 102/03/0449 „New circuit devices for communication technology“.

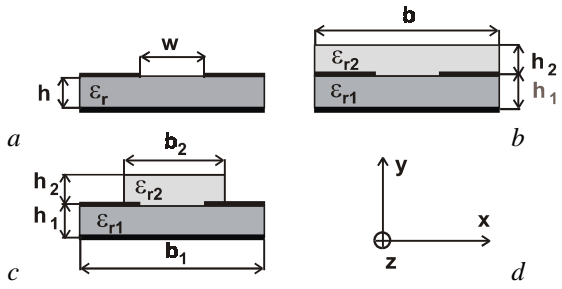

Fig. 1 Cross-section of the CBSL, the MCBSL and the MCBSL with reduced upper layer width, coordinate system.

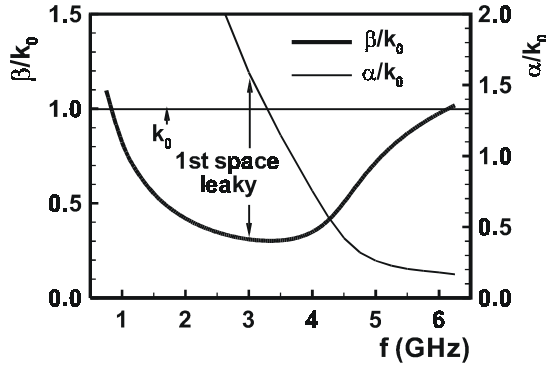

Fig. 2 Dispersion characteristic of the 1st space leaky mode on the CBSL with $w=30$ mm, $h=15$ mm, $\epsilon_r=2.6$.

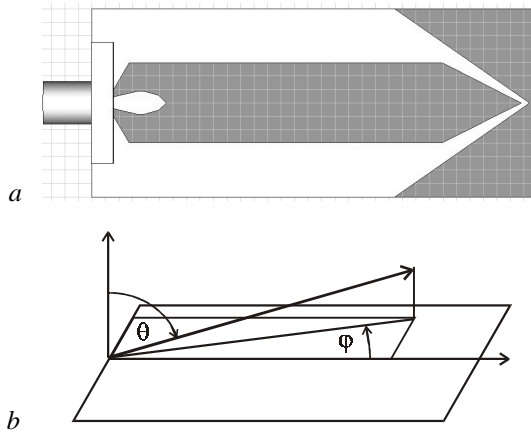

Fig. 3 The CBSL leaky wave antenna layout - a, orientation of spherical coordinates - b.

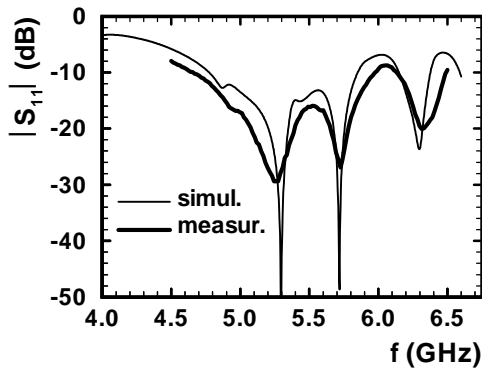

Fig. 4 Measured and calculated return loss of the antenna from Fig. 3a with $w=30$ mm, $h=15$ mm, $\epsilon_r=2.6$, $b=70$ mm.

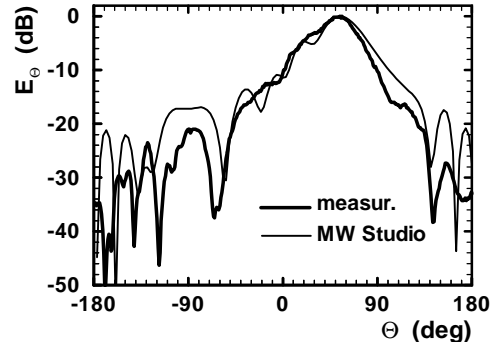

Fig. 5 The measured and calculated antenna radiation pattern in the plane $\phi=0$ deg at 5.25 GHz.

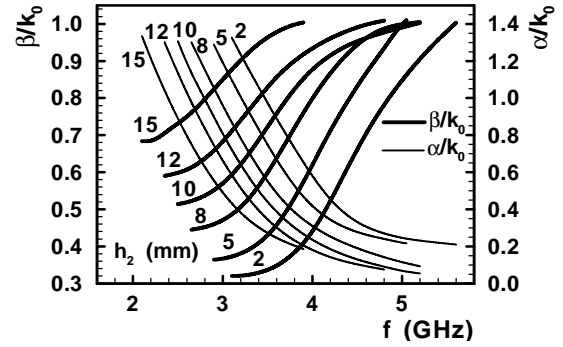

Fig. 6 Dispersion characteristics of the 1st space leaky mode on the MCBSL with $w=30$ mm, $h_1=15$ mm, $\epsilon_{r1}=\epsilon_{r2}=2.6$ calculated for various h_2 .

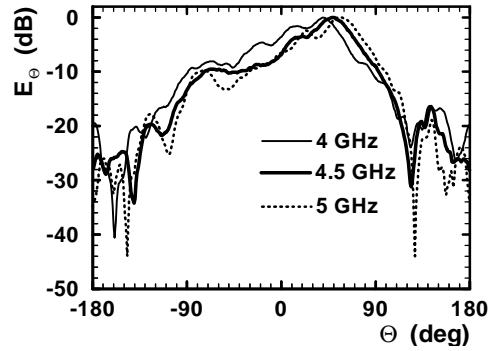

Fig. 7 Measured radiation patterns of the MCBSL antenna with $w=30$ mm, $h_1=15$ mm, $h_2=10$ mm, $\epsilon_{r1}=\epsilon_{r2}=2.6$, $b_1=70$ mm, $b_2=31$ mm, in the plane $\phi=0$ deg.

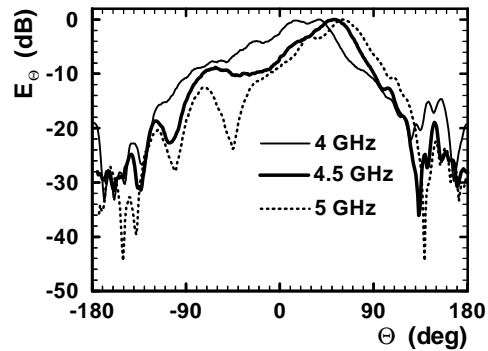

Fig. 8 Measured radiation patterns of the MCBSL antenna with $w=30$ mm, $h_1=15$ mm, $h_2=5$ mm, $\epsilon_{r1}=\epsilon_{r2}=2.6$, $b_1=70$ mm, $b_2=31$ mm, in the plane $\phi=0$ deg.